

Marine Maintenance-Free Starting Battery



BB N150 12V150Ah Marine Battery



- CQW Mrine Battery
- Maintenance-free marine battery
- No need to refill electrolyte
- No need for equalisation charging
- CCS Certification
- Valve-regulated sealed structure

SPECIFICATION:

Brand	BB	Authoritative Certification	CCS Certification
Model	6-CQW-150	Voltage	12V
Starting Current CCA (25 °C)	830A	Marine Cranking Amps MCA (25 °C)	1079A
Dimension	508×220×218 (245) mm	Terminal Type	L
Package Dimensions	513×228×302 mm	Operating temperature range	10.5V - 14.4V
Weight (N / G)	33.5kg / 35.8kg	Cyclic Charge Voltage	20 °C - 25 °C

Battery Dimension

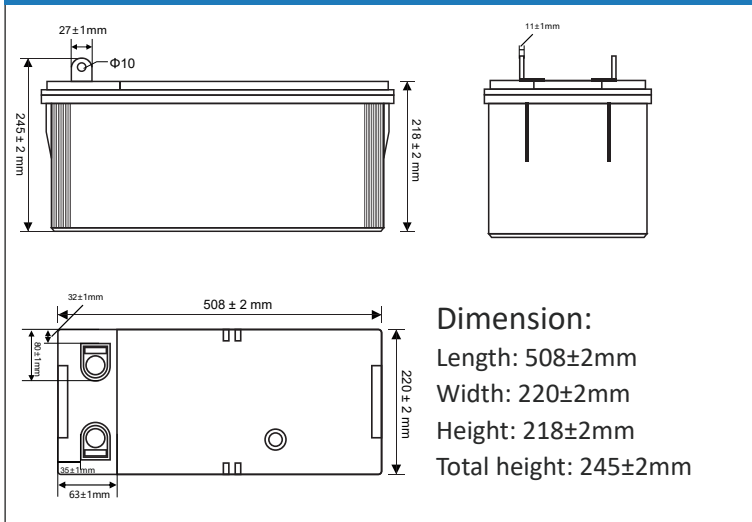

Battery Characteristics

Starting Current CCA(25°C)	830A	
Reserve Capacity(RC)	132min	
Rated Capacity	20-hour rate(C20)	150Ah

Stand terminals & Polarity

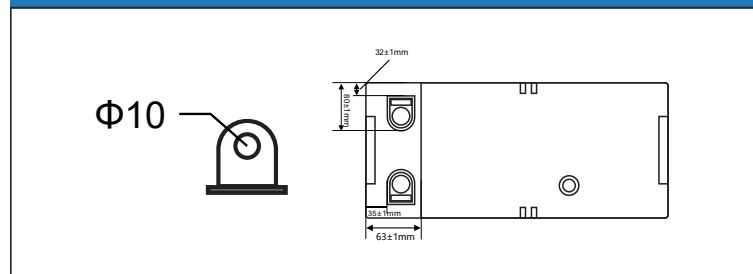

Disclaimer
 Accuracy of all technical data and information are provided to the best knowledge of the manufacturer.
 Properties, specifications and application parameters are subject to change without notice. The manufacturer does not undertake any liability of any kind whatsoever.

Powering Your Voyage

Powering the World's Fleets. From small fishing boats to large commercial vessels, BB batteries provide the power you need. Our customizable solutions ensure that you get the perfect battery for your specific application.

